

# Instruction manual

notion.A Computer

Protection class IP65

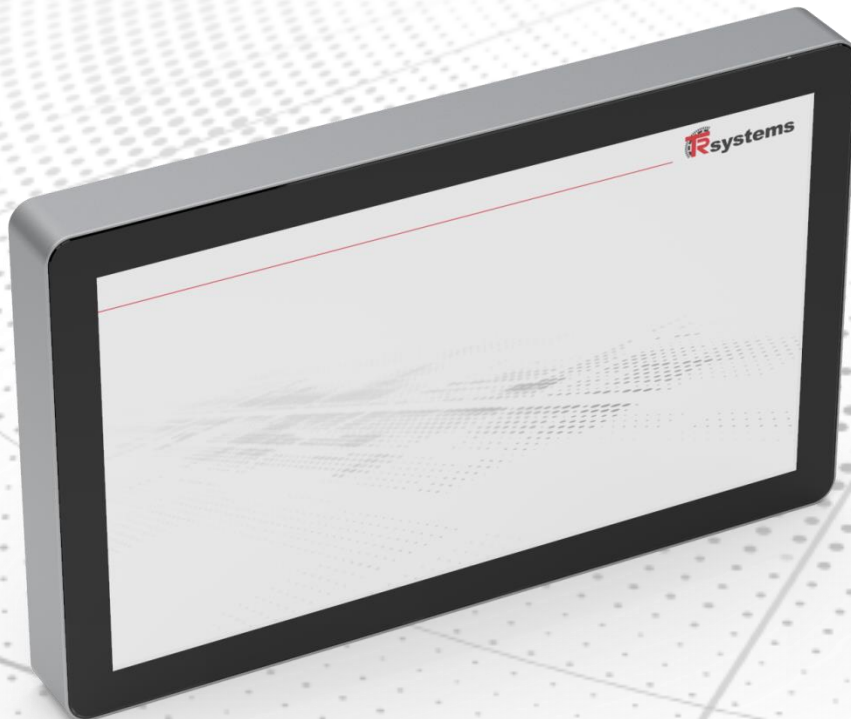

**notion**

Original version (GB)

## Index

|   |           |
|---|-----------|
| <b>INDEX .....</b>  | <b>2</b>  |
| <b>1. TO THIS MANUAL.....</b>                                     | <b>3</b>  |
| 1.1. Release .....  | 3         |
| 1.2. Index of changes .....                                       | 3         |
| <b>2. SAFETY INSTRUCTIONS .....</b>                               | <b>4</b>  |
| <b>3. DESCRIPTION .....</b>                                       | <b>6</b>  |
| 3.1. Basic safety instructions .....                              | 6         |
| 3.2. Intended Use .....   | 6         |
| 3.3. Non-approved use .....                                       | 7         |
| 3.4. Responsibility of the operator.....                          | 8         |
| <b>4. SCOPE OF DELIVERY .....</b>                                 | <b>10</b> |
| <b>5. SIGNAL DISPLAYS.....</b>                                    | <b>14</b> |
| <b>6. MONTAGE.....</b>  | <b>15</b> |
| 6.1. Connecting the operating system.....                         | 17        |
| <b>7. INSTALLATION AND INITIAL COMMISSIONING .....</b>            | <b>18</b> |
| <b>8. FAULTS.....</b>   | <b>18</b> |
| 8.1. In case of fire.....   | 18        |
| <b>9. TYPE PLATE.....</b>   | <b>19</b> |
| <b>10. TECHNICAL DATA .....</b>                                   | <b>19</b> |
| 10.1. Technical data notion.A Computer Protection class IP65..... | 19        |
| <b>11. DISASSEMBLY AND DISPOSAL .....</b>                         | <b>22</b> |

## 1. To this manual

### Copyright and Disclaimer

This manual, including the illustrations it contains, is intended for use by protected by copyright. Third-party applications of this manual that may be used by the copyright regulations are prohibited. Reproduction, Translation as well as electronic and photographic archiving and modification requires the written approval of the manufacturer. Violations obligate to pay damages. Intended use:  
Exclusively for industrial environment!

### Brands

The products, names and logos mentioned are used exclusively for the following purposes and may be trademarks of their respective owners, without any special marking.

### 1.1. Release

|                                   |                      |   |            |
|-----------------------------------|----------------------|---|------------|
| <b>Purpose of the instruction</b> |                      | Increase in quality, in the sense of the company's guiding principles |            |
| <b>Author</b>                     | <b>Creation date</b> | MAS   | 27.07.2018 |
| <b>Release by</b>                 |                      | MAS   |            |
|                                   |                      | SCS   |            |
| <b>Document number</b>            |                      | TRS-DOC-001418  |            |

### 1.2. Index of changes

On this page of the document the current version with the corresponding date and author is noted. Drawings that may be attached are provided with their own modification index.

| Version | Change                            | Reason for change | Date     | Author |
|---------|-----------------------------------|-------------------|----------|--------|
| 00      | Created                           |                   | 27.07.18 | SCM    |
| 01      | Extension by Notion.A<br>15,6"    |                   | 01.08.18 | SCM    |
| 02      | Supplement<br>"About this manual" | Management needs  | 08.10.18 | MAS    |

### General information

Read this manual carefully before use and keep it in a safe place.  
Pass the manual on to the user after installation and, if resold, with the product.

### Target audience

This manual is intended for persons who commission, configure, operate and maintain a product.

### Explanation of terms

Terms are listed in the table (Tab. 1) and briefly explained for the introduction. Some terms are described in detail in the chapter "System Overview".

| Term        | Statement  |
|-------------|--|
| <b>User</b> | Users are persons who have been created in the system. |

Table 1 Definition of terms

## 2. Safety instructions

**Classification of notes**

These operating instructions contain instructions which you must observe for your personal safety and to avoid damage to property. A distinction is made between basic safety instructions and warnings.

**Safety instructions**

The basic safety instructions precede the manual. The chapter "Safety instructions" warns of fundamental dangers which can occur in several phases of product application and which must always be observed by the product user.

**Warnings**

Warnings are placed within the documents at the specific hazard locations. They are immediately before the action where danger exists. The warning notices are highlighted by a warning triangle and are displayed as follows depending on the degree of danger:





| Warning signs   | Significance  |
|---|---|
|    | DANGER indicates an imminently hazardous situation which, if not avoided, will result in death or serious injury.   |
|   | WARNING indicates a potentially hazardous situation which, if not avoided, could result in death or serious injury. |
|  | CAUTION indicates a potentially hazardous situation which, if not avoided, may result in minor or moderate injury.  |
|  | CAUTION indicates a situation which, if not avoided, may result in property damage.                                 |

Table 2.1: Type of safety advice

**Structure of Warnings**

The SAFE method is a procedure for the systematic design of safety instructions. The acronym SAFE stands for the four principles:

- Danger severity (signal word)
- Type and source of danger
- Consequences of disregarding the danger
- Escape (measures to avert danger)

Example:

**! WARNING**

**Danger of cuts due to sharp-edged sheets.**  
 It can lead to cuts.

- ▶ Wear cut-resistant gloves
- ▶ If possible, deburr the sharp edges of the sheets.

|  |  |
|--|--|
| <b>Misapplication</b>                  | Nature and source of danger                    |
| <b>Warning signs</b>                   | Warning sign according to the following table. |
| <b>Reasons for misuse</b>              | Describes possible reasons for misuse.         |
| <b>Possible consequences of misuse</b> | Describes the consequences of non-compliance.  |
| <b>Security measure</b>                | Indicates how to avoid danger..                |

Table 2.2: Structure of a Safety Notice.

Additional information:

Example ESD area:



ESD protective measures according to DIN EN 61340-5-1 must be observed.

Example Reference:



Refer to chapter X.X. for the corresponding structure.

### 3. Description

This chapter describes the basic functionality of the product.

Product notion.A Computer

The product notion.A Computer is an operating system for visualization and operation based on an X86 industrial controller.

#### 3.1. Basic safety instructions

This chapter describes basic safety requirements and important information for the safe installation of the product. The product has been manufactured in accordance with the generally accepted rules of technology. Nevertheless, there is a risk of personal injury and damage to property if you do not observe this chapter and the safety instructions in this documentation.

- Read this documentation thoroughly and completely before working with the product.
- Keep the documentation in such a way that it is accessible to all users at all times.
- Always pass the product on to third parties together with the required documentation.

#### 3.2. Intended Use

The product is intended exclusively for industrial use and not for private use.

The notion.A Computer operating system is designed for industrial use in machine and plant engineering.

In addition to an integrated computing unit, a TFT display and a touch screen are built into an aluminium/plastic housing. Mounting is via the 4 or 8 mounting holes in the rear wall or the mounting arm adapter (optional).

### 3.3. Non-approved use

The manufacturer accepts no liability for damage caused by improper use. The risks associated with improper use are the sole responsibility of the user.

Non-intended use of the product and, if present, its components:

- any other use than described in the intended use and as described in the respective documentation.
- that it is used in applications not expressly approved by the manufacturer. Please note the statements in the safety instructions of the respective documentation!
- the structural alteration that destroys the original condition.
- improper programming or configuration of the system.
- The responsibility and risks for the programming and configuration of the system lie solely with the user.
- Do not work with the product in potentially explosive atmospheres containing flammable liquids, gases or dust.
- the operating system must not be used in hazardous areas. .
- the use in all types of security relevant applications

**The following paragraph is required in normative terms. Due to the equipment and its condition, the use in the living area is prohibited without exception! So-called "appropriate measures" can only be provided by the manufacturer, but are not intended. Unauthorized measures are strictly forbidden for the operator and fulfil the conditions of "improper use"!**

**Important!**  
**This is a Class A facility. This device can cause radio interference in living areas. In this case, the operator may be required to take appropriate measures.**

### 3.4. Responsibility of the operator

Definition of the term "operator"

The operator is the person who operates the machine himself for commercial or economic purposes or who leaves it to a third party for use/application and who bears the legal product responsibility for the protection of the user, the personnel or third parties during operation.

#### **operator obligations**

The product may not be modified, added to or converted without the consent of the manufacturer. The operator must ensure that

- Know and implement the applicable occupational health and safety regulations
- Identify risks arising from the working conditions at the place of use in a risk assessment.
- Create operating instructions for the operation of the product
- Regularly check whether the operating instructions correspond to the current status of the regulations.
- Clearly regulate and define the responsibility for installation, operation, troubleshooting, maintenance and cleaning
- Ensure that all employees (especially users) have read and understood the instructions.
- Train the personnel at regular intervals and inform them about the dangers.
- Provide personnel with the necessary protective equipment.
- The operator must ensure that the safety and danger information on the machine / system is observed and that the information signs are in a clearly legible condition.

#### **Technical condition**

The product may only be used in a technically perfect condition and in accordance with its intended use, safety and hazard awareness in compliance with the relevant regulations. Any faults detected, in particular those which could impair safety, must be rectified immediately.

#### **Compliance**

The operator must ensure by means of suitable organisational and instruction measures that the relevant safety regulations and safety rules are observed by the persons entrusted with the operation, maintenance and repair of the product.

#### **Behavioural control**

The operator must check the safety and danger-conscious behaviour of the personnel.

#### **Warranty and Liability**

In principle, the "General Terms and Conditions" of the manufacturer apply. These are available to the operator at the latest with the order confirmation or with the conclusion of the contract. Warranty and liability claims for personal injury and damage to property are excluded.

**Selection and qualification of personnel; basic duties**

All work on the product may only be carried out by qualified personnel. Qualified personnel are persons who, on the basis of their training, experience and instruction as well as their knowledge of relevant standards, regulations, accident prevention regulations and operating conditions, have been authorised by the person responsible for the safety of the system to carry out the necessary activities. They are able to recognize and avoid possible dangers.

The standards VDE 0105-100 and IEC 364 must also be consulted for the definition of "qualified personnel" (sources of supply e.g. Beuth Verlag GmbH, VDE-Verlag GmbH).

Responsibility for assembly, installation, commissioning and operation must be clearly defined.

There is an obligation to supervise personnel to be trained or instructed.

**General safety instructions**

- Observe the accident prevention and environmental protection regulations applicable in your country.
- Observe the safety regulations of the country in which the product is used.
- Persons who assemble, operate, dismantle or maintain products must not be under the influence of alcohol, other drugs or medications which influence the reactivity.
- Only use accessories and spare parts approved by the manufacturer.

**Product- and technology-dependent safety instructions**

In this chapter, basic safety instructions are listed, which depend on the technology used in the product.

**General accident prevention regulations**

The basic prerequisite for safe working is compliance with all safety instructions! In addition to the instructions in this manual, the local accident prevention and environmental regulations as well as the national industrial safety regulations apply.

**Working in a de-energized state**

All work must be carried out without voltage in accordance with the safety regulations.

**Transport / Storage** During transport and storage, the device must be protected from impermissible stress (mechanical stress, temperature, humidity, aggressive atmosphere). The product is an operating system and must be handled with appropriate care. Incorrect handling may result in damage to the product. A correct operation is no longer guaranteed (see chapter "Technical condition").

**Danger of damage to the unit!** When transporting the device in cold weather or when the device is subject to extreme temperature fluctuations, be sure to observe the following is exposed to the fact that no moisture (condensation) is deposited on and in the device.

**Storage conditions** The following points must be observed:

- Do not drop the product or subject it to major vibrations.
- Do not store outdoors
- Dry and dust-free storage
- Do not expose to aggressive media (unless the system is designed for this purpose)
- Do not expose directly to solar radiation
- Avoid mechanical vibrations

**Transport inspection** If the packaging is damaged, the product must be checked for proper function. The check must be carried out by qualified personnel (see chapter "Personnel selection..."). Do not throw away the original packaging. Keep it for future transport.

## 4. Scope of delivery

The scope of delivery of the system depends on the respective configuration, i.e. the selected components. The system consists of the following components:

| Number | Description of the |
|--------|--------------------|
| 1x     | Perating system    |
| 1x     | Documentation      |

**Description of the complete system** Notion.A Computer is designed exclusively for industrial applications. It is a robust system, which is used in industrial environments as an operating and display system.

### connector description

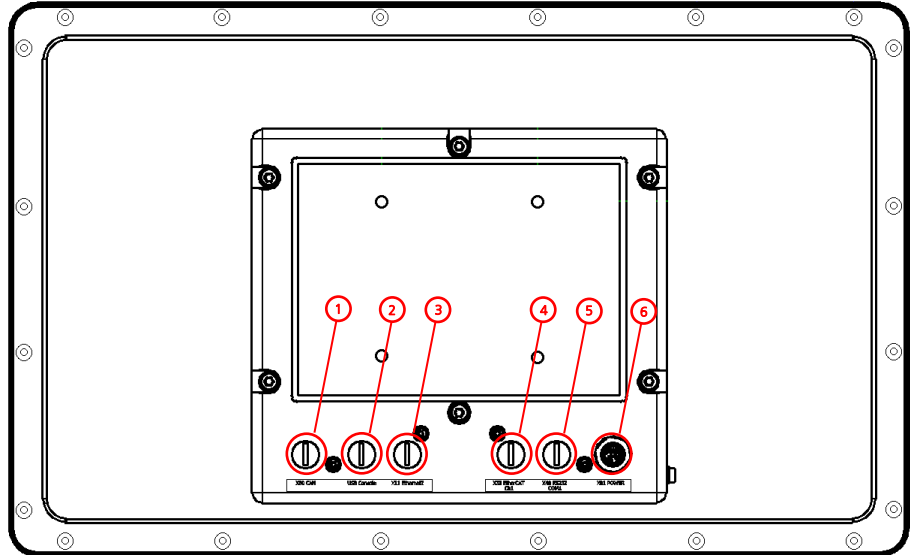



View: back side

| Interface - Pos. | Denomination      | Function          |
|------------------|-------------------|-------------------|
| 1                | X30-CAN           | Fieldbus          |
| 2                | USB Serial Debug  | Service interface |
| 3                | X11 Ethernet2     | Network interface |
| 4                | X10 Ethernet1     | Network interface |
| 5                | X40 RS232<br>COM1 | Serial interface  |
| 6                | X01 Power         | Power supply      |

### Pin assignment

| 1   |  | X30 CAN*   |               |
|---|--|------------|---------------|
| A-codiert   |  | <b>Pin</b> | <b>Signal</b> |
|  |  | 1          | Shield        |
|   |  | 2          | NC            |
|   |  | 3          | CAN_GND       |
|   |  | 4          | CAN_H         |
|   |  | 5          | CAN_L         |

| 2   |  | USB-OTG/USB Serial Debug |               |
|---|--|--------------------------|---------------|
| A-codiert   |  | <b>Pin</b>               | <b>Signal</b> |
|  |  | 1                        | +5 V          |
|   |  | 2                        | Data -        |
|   |  | 3                        | Data +        |
|   |  | 4                        | GND           |
|   |  | 5                        | NC            |

| 3 X11 Ethernet2*   |     |        |
|--|-----|--------|
| D-codiert<br><br> | Pin | Signal |
|  | 1   | TX+    |
|  | 2   | RX+    |
|  | 3   | TX-    |
|  | 4   | RX-    |

| 4 X10 Ethernet1  |     |        |
|--|-----|--------|
| D-codiert<br><br> | Pin | Signal |
|  | 1   | TX+    |
|  | 2   | RX+    |
|  | 3   | TX-    |
|  | 4   | RX-    |

| 5 X40 RS232 COM1*  |     |        |
|--|-----|--------|
| A-codiert<br><br> | Pin | Signal |
|  | 1   | NC     |
|  | 2   | TX     |
|  | 3   | GND    |
|  | 4   | RX     |
|  | 5   | Shield |

| 6 X01 Power  |     |        |
|--|-----|--------|
| T-codiert<br><br> | Pin | Signal |
|  | 1   | +24VDC |
|  | 2   | NC     |
|  | 3   | GND    |
|  | 4   | NC     |

\* Configuration dependency

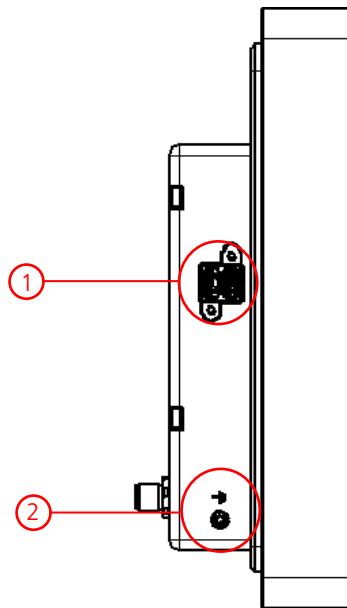

Ansicht: Linke Seite

| Interfaces - Pos. | Designation                  | Function  |
|-------------------|------------------------------|---|
| 1                 | USB 2.0                      | Data transfer   |
| 2                 | Grounding / functional earth | The equipotential bonding of the operating system is established via the earthing hole on the rear of the housing. Screw size max. M4x8.<br><b>Must be connected!</b> |

| 1          |     |        |
|------------|-----|--------|
| 2x USB 2.0 |     |        |
|            | Pin | Signal |
|            | 1   | +5VDC  |
|            | 2   | Data - |
|            | 3   | Data + |
|            | 4   | GND    |
|            | 5   | +5VDC  |
|            | 6   | Data - |
|            | 7   | Data + |
|            | 8   | GND    |

## 5. Signal displays

a ) notion.A 15,6"

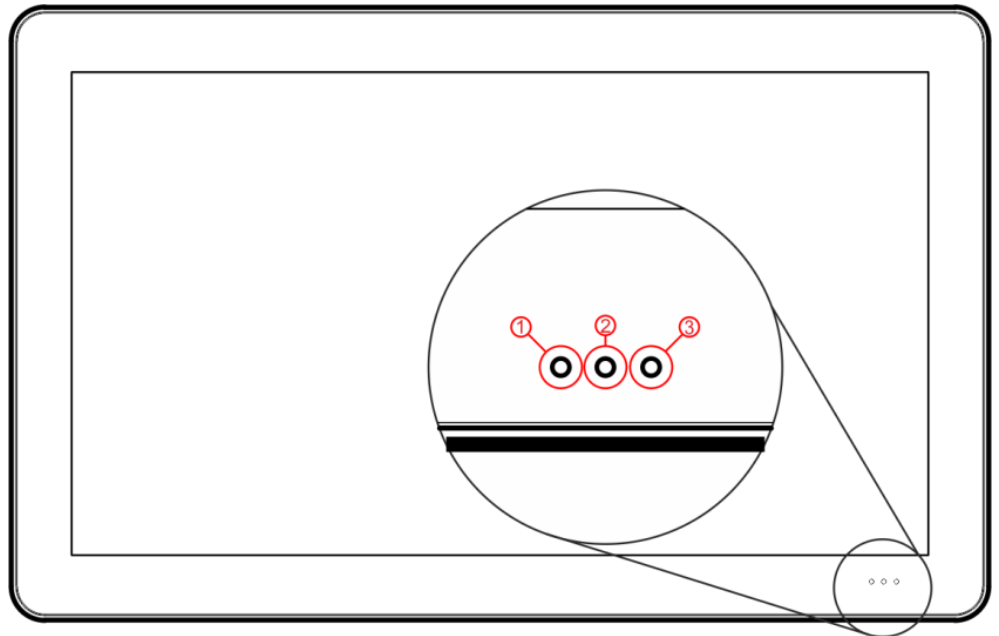

| Signal -Pos. | Signal - Color | Function   |
|--------------|----------------|--|
| 3            | Blau           | Ready for operation<br>→ Codesys* function in RUN mode |
| 2            | Grün           | Device in boot process                                 |
| 1            | Rot            | CAP buffer* active - data storage and Codesys shutdown |

\* CAP buffer (short-term energy memory for controlled system shutdown) and software codesys(3S) sind

**Configuration-dependent**

b) notion.A 17,3"

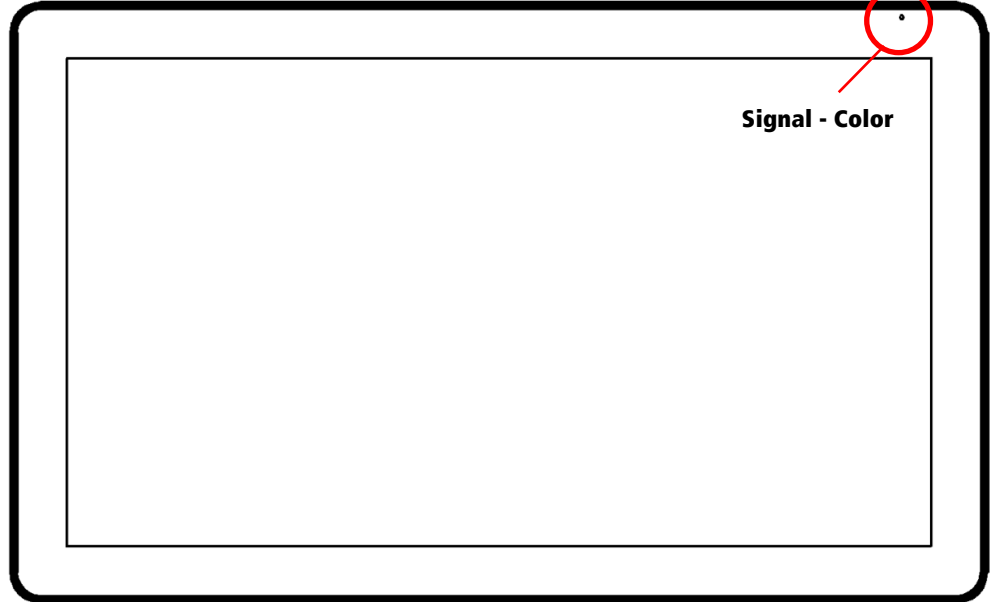

Ansicht: Frontal

| Signal - Farbe | Function   |
|----------------|--|
| Blue           | Ready for operation<br>→ Function CODESYS* - Control in "RUN" mode |
| Green          | → Function CODESYS* - Device in boot process                       |
| Red            | → Function CODESYS* CAP-Buffer* active - Data storage and shutdown |

\* CAP buffers (short-term energy storage for controlled system shutdown) and software codesys(3S) are **configuration-dependent**.

## 6. Montage

### Attachment dimensions

The device must be mounted with the orientation shown here. The industrial operating system must be mounted on a system designed for the device and its static and dynamic loads.

a) notion.A 15,6"

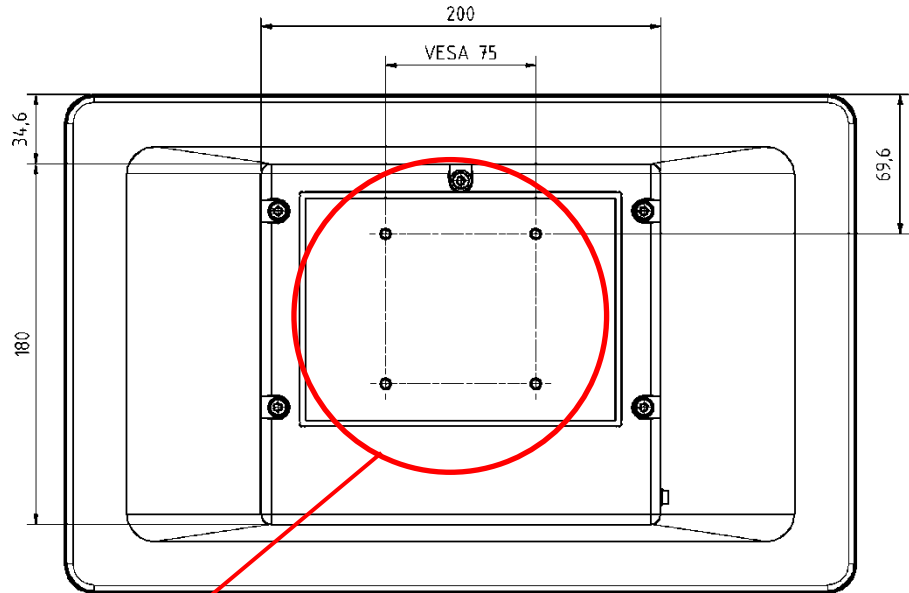

- Thread M6
- Maximum screw-in depth 6.5 mm

b) notion.A 17,3"

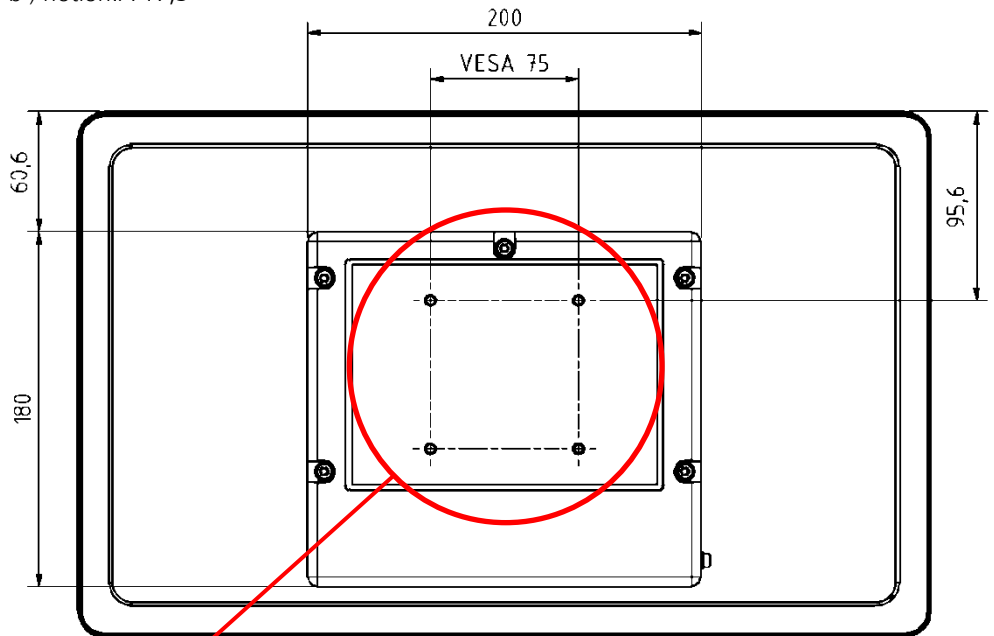

- Thread M6
- Maximum screw-in depth 6.5 mm

## 6.1. Connecting the operating system

The connection on the operating system must never be connected or disconnected in hazardous areas! Danger of explosion!

The power supply plug of the operating system must be disconnected!  
Do not plug in or unplug the plug while it is live!

Read the documentation on the external devices before connecting them!  
Do not connect or disconnect the cables during a thunderstorm!  
When disconnecting a cable, always touch the plug. Do not pull on the cable

### Connecting the line

The connections are located at the rear and on the side of the operating system and are described in chapter "Connection / pin assignment" is documented.

When connecting cables to the operating system, follow the sequence described below:

- Disconnect the operating system from the power supply.
- Connect all cables to the operating system and to the devices to be connected.
- Make sure that all screw connections between plugs and sockets are properly tightened!
- Reconnect all devices to the power supply.

### Equipotential bonding

Connect to the connection point for potential equalisation. The equipotential bonding of the operating system is established via the earthing hole on the rear of the housing. Must be connected!

### Switching the operating system on and off

The operating system does not have its own power switch. When the power supply is switched on, the operating system is also started.

### First shut down, then switch off!

If you have shut down the operating system, you must switch it off for at least 1 minute before you can restart it. After switching on the supply voltage again, the operating system then starts automatically.

### Operating

The touch screen of the operating system may only be operated with the finger or touch pen (not included in the scope of delivery). Operation with other objects can lead to destruction of the device.

## 7. Installation and initial commissioning

- Operating systems** Configuration-dependent
- Optional software** Configuration-dependent

## 8. Faults



For fault indication see also chapter "Signal indication".

| Disruption  | Cause   | Measure  |
|---|---|--|
| No function of the operating system   | Fehlende Stromversorgung des Betriebssystems  | Check power supply cable<br>Connect the cable correctly<br>Contact TRsystems Service |
| Operating system boots, software is started, does not work properly               | The cause of the error is the software installed by the supplier of the operating system. | Contact the device or software manufacturer.   |
| The operating system functions only partially or only temporarily, e.g. no image. |   | Contact TRsystems Service  |

- Maintenance and cleaning** Maintenance or cleaning is only permitted when the unit is switched off!
- Cleaning the operating system** Switch off the operating system and all connected devices. The front of the operating system can be cleaned with a damp, soft cloth. Do not use caustic cleaning agents, thinner, abrasive cleaners, or hard objects that could cause scratches.
- Maintenance** The operating system is maintenance-free.

### 8.1. In case of fire

In case of a fire, the operating system must be extinguished with powder or nitrogen.

## 9. Type plate

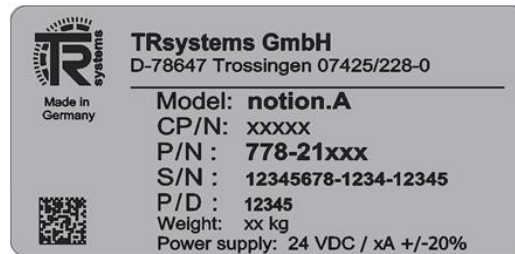

Exemplary nameplate

## 10. Technical data

### 10.1. Technical data notion.A Computer Protection class IP65

| Trait                                | Characteristic value   |
|--------------------------------------|--|
| Electrical operating voltage         | 24 VDC $\pm$ 20 %  |
| protection class                     | IP65 Front<br>IP65 Back  |
| Ambient temperature during operation | 0 to 40 °C   |
| Ambient temperature Storage          | -20 to 60 °C   |
| Relative humidity                    | 10-90 % no condensation  |
| Operating system                     | glass touch  |
| Fastening systems                    | Vesa 75*   |
| Display format                       | 16:9   |
| Display resolution                   | 1366x768 / 1920x1080*  |
| CPU                                  | X86- Architecture - Processor Class<br>Intel® Atom or Celeron                |
| Main memory                          | 4 GByte*   |
| Storage media                        | eMMC* - 16 GByte or 32 GByte SSD*<br>HDD*                                    |
| Operating system                     | Microsoft® Windows*<br>Linux*  |
| Communication                        | Ethernet<br>USB 2.0<br>RS232*<br>RS485*                                      |
| Options                              | Cap Buffer* (short-term energy<br>storage for controlled<br>system shutdown) |

\* Configuration-dependent

Technical drawing a) notion A 15,6" 396,3

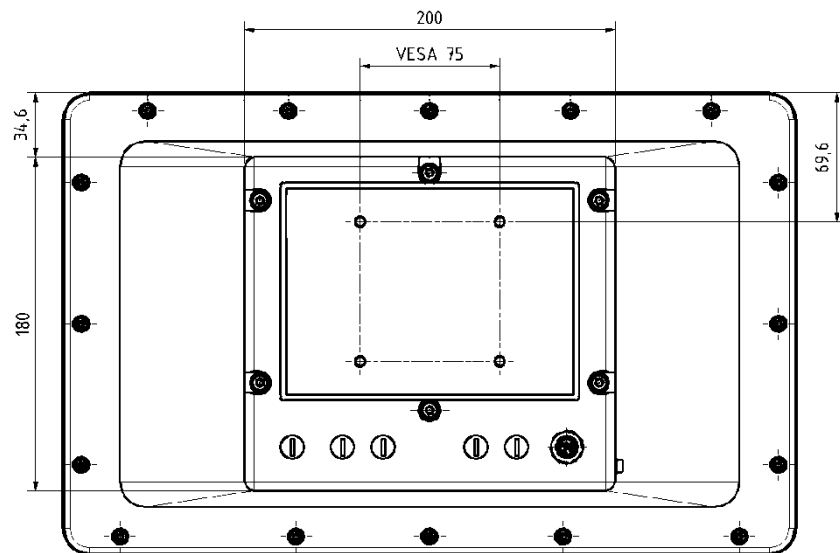
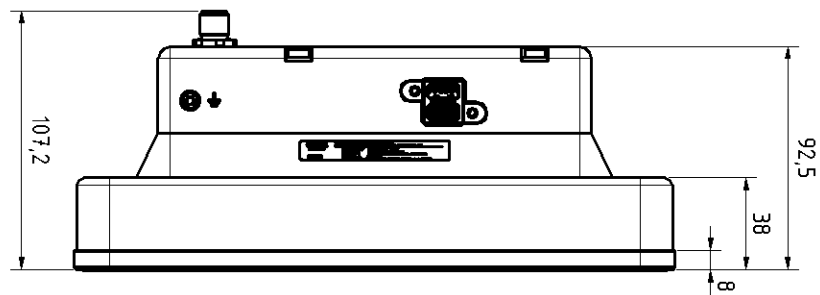
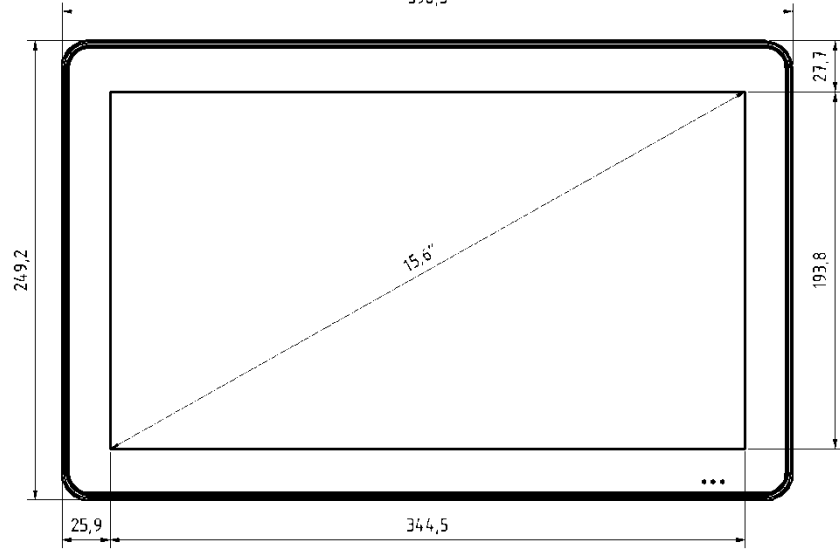

b) notion.A 17,3"

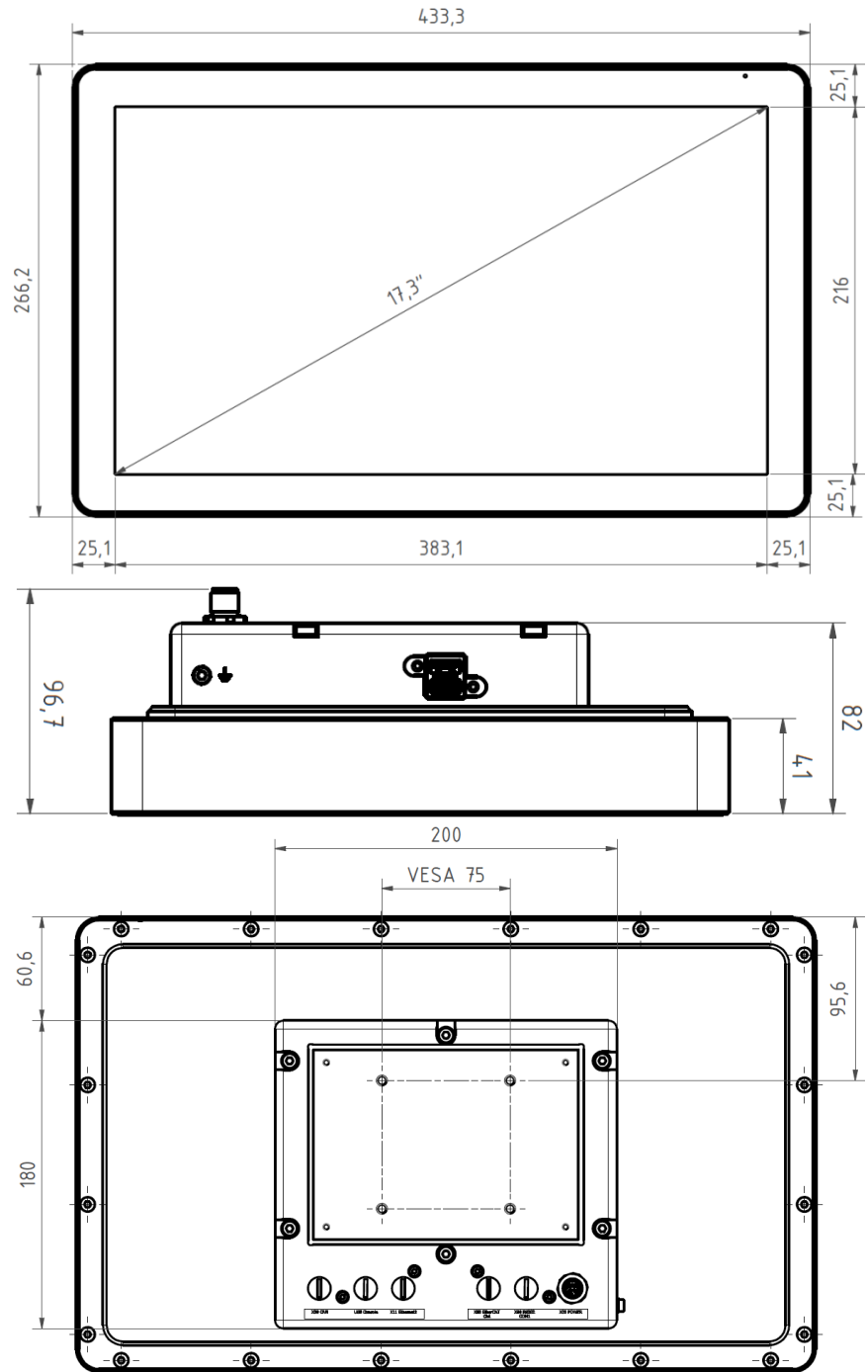

## 11. Disassembly and disposal

Dispose of the device in accordance with national and legal environmental regulations.



TRsystems GmbH  
Eglisshalde 16  
D-78647 Trossingen

phone: +49 (0) 7425 / 228 - 0  
telefax: +49 (0) 7425 / 228 - 34

mail: [info@trsystems.de](mailto:info@trsystems.de)  
web: [www.trsystems.de](http://www.trsystems.de)